

# CADfix Viz *Optimize 3D CAD Model Assets for VR/AR/MR*



CADfix Viz streamlines integration processes and maximizes the reuse of 3D Digital Assets in VR/AR/MR applications. Large and complex 3D mechanical CAD assemblies can be automatically converted into optimized lightweight, low triangle meshes, utilizing robust mesh generation, powerful defeaturing tools, and intelligent decimation algorithms.

Orders of magnitude in file size and triangle count reduction can be achieved ahead of integration of models into visualization systems and staging applications.

## MCAD Imports

- CATIA
- Creo
- DXF/DWG
- Inventor
- JT
- NX
- Parasolid
- SAT
- Solid Edge
- SOLIDWORKS
- STEP

## Mesh Imports

- FBX
- glTF/GLB
- OBJL

## Mesh Exports

- FBX
- glTF/GLB
- JT
- OBJ
- Unity Software (FBX)
- Unreal Software (FBX)
- USD
- VRML
- XGL/ZGL

### *VR/AR/MR application designers, with no MCAD modeling experience can quickly and easily:*

- Generate mesh models at multiple LODs
- Remove unwanted small parts and invisible internal parts
- Remove unnecessary CAD features such as holes, protrusions, logos and text
- Decimate dense meshes in complex areas
- Wrap complex parts while retaining key features
- Generate and optimize assembly hierarchies

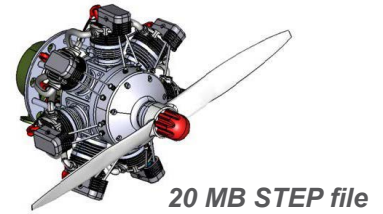

20 MB STEP file

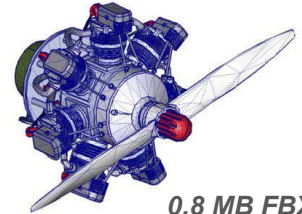

0.8 MB FBX file  
9494 Triangles

### *CADfix Viz Benefits:*

- Significantly reduce file size
- Generate low triangle count mesh
- Improved display speed in VR/AR/MR
- Reduce lead time
- Eliminate import failures
- Avoid CAD rework
- Produce legible models
- Eliminate system hangs

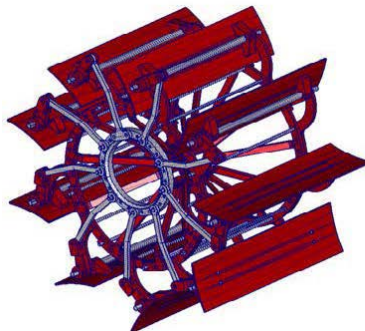

7694 Triangles

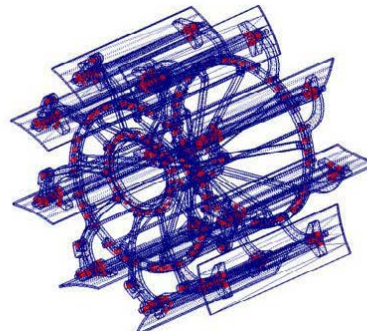

Automatically remove holes

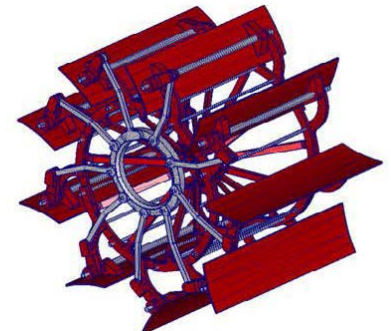

2736 Triangles

These materials are not sponsored by or affiliated with Unity Technologies or its affiliates. "Unity" is a trademark or registered trademark of Unity Technologies or its affiliates in the U.S. and elsewhere. Unreal® is a trademark or registered trademark of Epic Games, Inc. in the United States of America and elsewhere. Unreal® Engine, Copyright 1998 – 2021, Epic Games, Inc. All rights reserved.

### About ITI, a Wipro company

ITI is the global leader providing reliable interoperability, validation, and migration solutions for product data and related systems. ITI solves complex product data interoperability problems so the world's leading manufacturers can focus on making great products. ITI is a wholly owned US-based subsidiary of Wipro, Ltd, and exists within the Wipro Engineering business. Wipro Engineering provides customers with a platform to innovate and engineer the next generation of products and platforms at scale.

www.iti-global.com  
info@iti-global.com  
1-800-783-9199  
5303 DuPont Circle  
Milford, OH 45150, USA